

m M



mapa

m

M



m

M



mãe

m

M



m M



mala

m M

m M



mala

m M

m M



mala

m M

m M



mala

m M

m M



mala

m M

m M



mala

m M

m M



mala

m M

m M



mala

m M

m M



mala

m M









# A história do O mémé come o mapa



Um dia, a Mimi pegou na sua mota e foi passear pelo campo. Como não conhecia o caminho, perdeu-se. Pegou num mapa e começou a orientar-se. um cordeirinho que passava saltou e comeu o mapa da Mimi. Muito zangada, ela foi a correr atrás do mémé. Uma mula amiga do cordeirinho pulou a mota da Mimi e quase lha desfez. com a voz autoritária, Mimi chamou os dois animais e ordenou-lhes:

- Para não fazerdes mais asneiras, ides escrever o “m” de mémé e de mula.

- Mas nós não andamos na escola nem precisamos de saber ler - disseram os dois animaizinhos.

- Não faz mal! O saber não ocupa lugar e é fácil aprender - afirmou Mimi.

- Então ensina-nos - pediu o mémé.

- É fácil! Só tendes que saltar três montes redondinhos no cimo, sem lhes tocar. Vamos lá: um... dois... três - explicou Mimi.

- Mé... mé... mé! Já sei fazer o “m” - dizia o cordeirinho sempre a saltar.

- Mu... mu... mu...! Já sei fazer o “m” - afirmava a mula, sempre a pular.

1º  
ANO

# PORTUGUÊS

RUBRICA :

Nome : \_\_\_\_\_

INFORMAÇÃO :

Data : \_\_\_/\_\_\_/\_\_\_

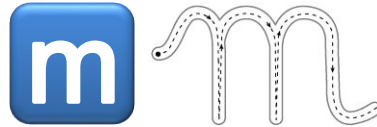

m

m

m

m

m

m



M

M

M

M

M

M

m M

m M

meia



ma

Ma

me

Me

mi

Mi

mo

Mo

mu

Mu

m M

m M

meia



ma

Ma

me

Me

mi

Mi

mo

Mo

mu

Mu

m M

m M

meia

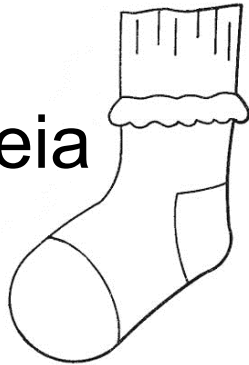

ma

Ma

me

Me

mi

Mi

mo

Mo

mu

Mu

m M

m M

meia

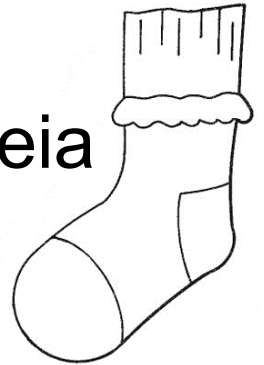

ma

Ma

me

Me

mi

Mi

mo

Mo

mu

Mu

**1º**  
ANO

# PORTUGUÊS

RUBRICA :

Nome : \_\_\_\_\_

INFORMAÇÃO :

Data : \_\_/\_\_/\_\_

\_\_\_\_\_











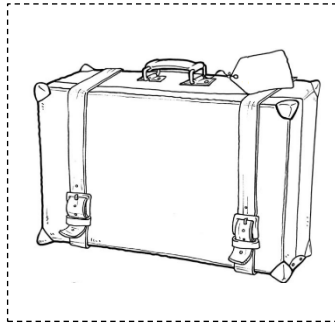
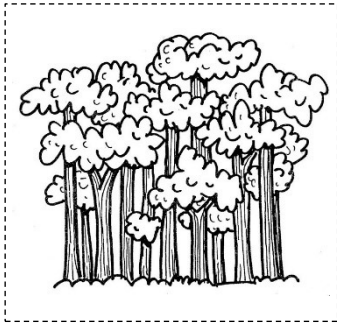
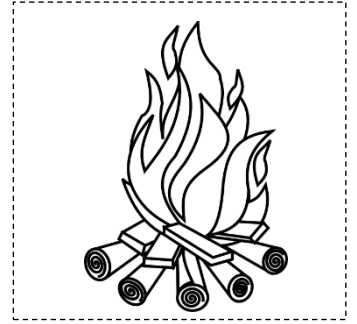
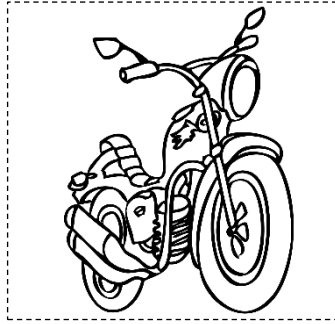
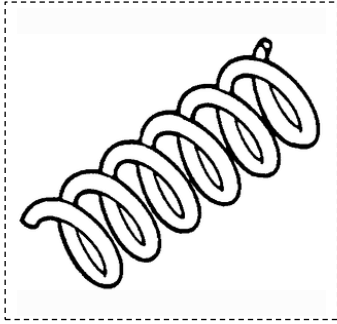
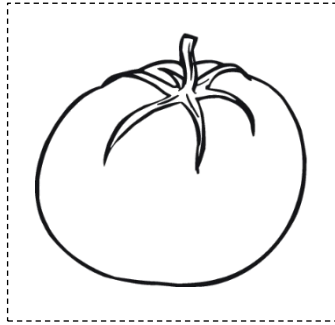
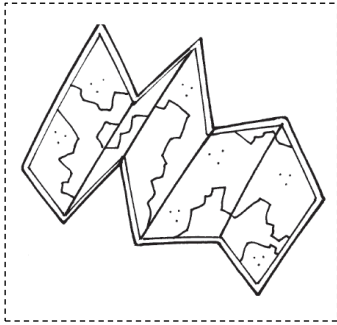

Pinta e recorta as imagens e as palavras. Depois cola-as correctamente na folha anterior.



**tomate**

**lume**

**mapa**

**modelo**

**meia**

**mata**

**mala**

**mota**

**mola**

*mata*

*meia*

*mala*

*mata*

*mapa*

*tomate*

*lume*

*mola*

*modelo*